

pro-cart

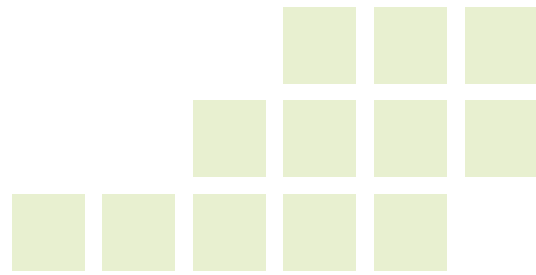

A STRONG TYPE FOR ALL CASES

The **pro-cart** mobile cart has a technically innovative and elegant design. The basic frame of this single-column cart carries a high load of up to 80kg / 176 lbs and its availability in different installation heights makes countless variations possible. The unique support column of the **pro-cart** offers various advantages. It allows separate routing of data and power cables and can even be equipped with an electric height adjustment mechanism. The column comes with rubber edges and a cover cap which allows for quick access to the cable and orderly cable management. The support column can also be locked so that the cables also remain protected from unauthorised access.

The **pro-cart** can be optionally equipped with a powerful isolating transformer (up to 1200 VA), making it the right choice for many medical applications.



A STRONG TYPE FOR ALL CASES



pro-cart

pro-cart is the professional choice in numerous areas of medical and laboratory technology, e.g. in anaesthesia, endoscopy, physiotherapy, ultrasound diagnostics. **pro-cart** demonstrates its true worth when it comes to heavy loads. This is guaranteed by the design of the base, which provides stability and safety despite low space requirement, and the high load rating. Its unique support column provides space for accessories as well as secure and invisible storage space for all electric components. Use of the entire adjustment depth means that even large items of equipment are accommodated with ease.



■ pro-cart Application for combined ultrasound and HF technology



■ pro-cart Application for preoperative ultrasound for image guided interventions



■ pro-cart Application for extracorporeal shock wave lithotripsy

pro-cart – THE HIGHLIGHTS AT A GLANCE

pro-cart

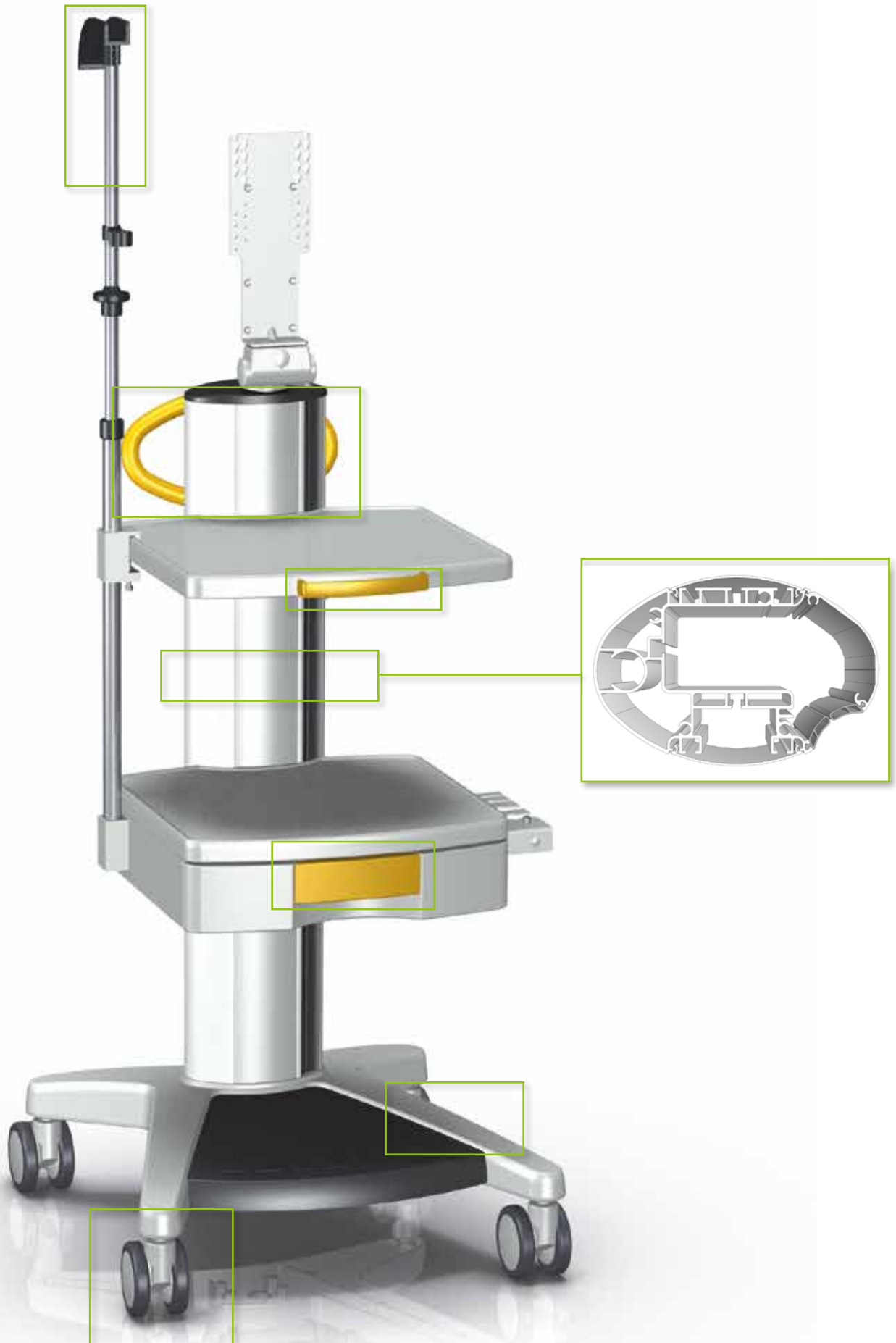

Spacious design options

- The vertical extrusion provides not only space for the attachment of components and accessories in a grid of 32/64 mm on the front and rear, but also for suction cup mounts, infusion stands and monitor mounts.

Functional ergonomics

- Optionally available mechanical and electrical height adjustments allow for easy positioning of controls and ensure that the user can adopt a natural posture in everyday work.
- The rear sliding handle can be folded down, allowing more legroom when the need to move a heavily loaded trolley arises. When folded up, the handle needs only a little space.
- The handle for opening the drawer also serves as a lock.

Comfortable electrification options

- Behind the inner vertical extrusion is a closable flap with enough space for socket strips with up to 6 slots for POAG connectors as well as for power supplies.
- Excess lengths of cables can be stowed away perfectly. Because of the two sealing lips, the cables can be run in or out at any height.
- Data lines can be fed through separate cable ducts at the front of the extrusion.

Efficient Elegance

- The shapely single-column- design plus extra components provides the **pro-cart** with lightness and openness.

Hygiene

- Cover strips and rubber strips leave no grooves open and allow for easy cleaning.
- The optional on/off switch is hygienically covered and housed in the support column and protected by the cap.
- The hygiene of all ITD products is validated with the certificate of the German Society for Hospital Hygiene (DGKH).

Robust materials

- The die-cast aluminium base can also accommodate a high-performance isolation transformer (up to 1200 VA) next to the supporting column.
- The shelves allow for a weight of up to 20 kg / 44 lbs each and have a width of 450 mm and an installation height of only 32 mm.

MODULARITY FOR NUMEROUS CONFIGURATION OPTIONS

The modular structure is the defining feature of the **pro-cart** mobile single-column equipment carts and the entire ITD product range, which allows all support systems to be configured, customised, upgraded or easily modified for special functions and application areas using the extensive standard range. This capability allows users to react fast and consistently to any changes or new customer requirements. The T-slots on the support column ensure easy assembly of the components. The display presented alongside shows a small selection of accessories for the **pro-cart** equipment carts.

pro-cart



1 The **block of drawers** is provided with a **mechanical one-hand lock** and this prevents unauthorised access.



2 The **keyboard drawer** has a low installation height and two adjustable bars prevent the keyboard from sliding about.





An **IV pole** with one-hand adjustment can easily be integrated in the **support column** without additional adapters.



The **swivel and tilt monitor holder** is designed for monitors with VESA 75 / 100 adaptation or universal adapter, depending on the version.



The **isolating transformer** – for reduction of earth-leakage currents from equipment – can be integrated in the basic frame to save space.

ORDER CONFIGURATIONS

pro-cart



pro-cart basic cart

Item number: PT.5000.XXX¹⁾

Equipment cart, 21 U (Total height: 884 mm), fitted with:

- 1 basic frame with 4 lockable twin castors Ø 100 mm
- 1 shelf with handle, front
- 1 shelf

Installation height: 21 U (672 mm)
Load capacity: 80 kg / 176 lbs
Finish: RAL 7035 light grey powder-coated
Decorative trims: handle see ¹⁾
Scope of delivery: assembled

pro-cart basic cart

Item number: PT.5001.XXX¹⁾

Equipment cart, 21 U (Total height: 884 mm), fitted with:

- 1 basic frame with 4 lockable twin castors Ø 100 mm
- 1 block of drawers with gel bottle holder, at the side
- 1 shelf
- 1 push handle, rear

Installation height: 21 U (672 mm)
Load capacity: 80 kg / 176 lbs
Finish: RAL 7035 light grey powder-coated
Decorative trims: handle and push handle see ¹⁾
Scope of delivery: assembled

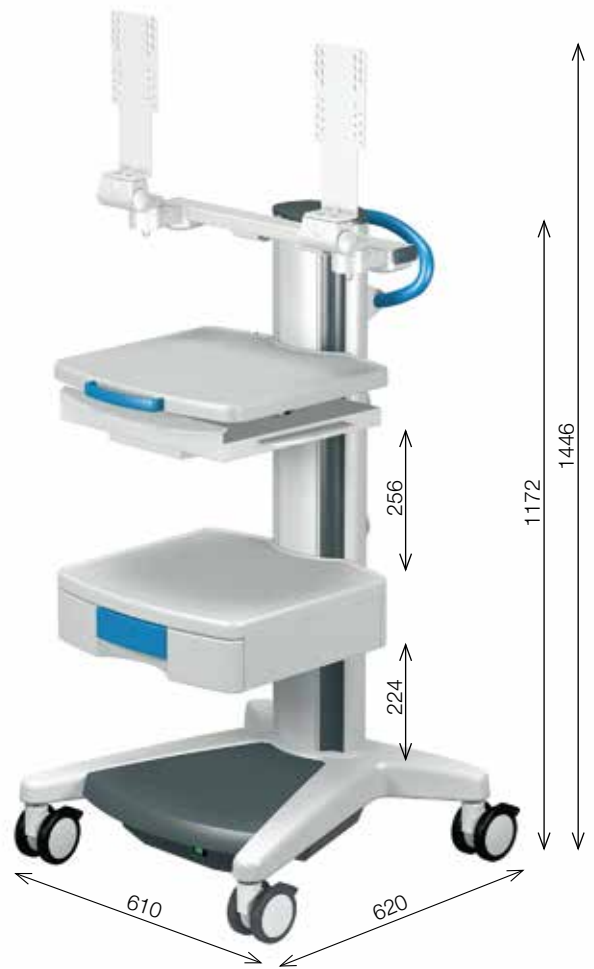
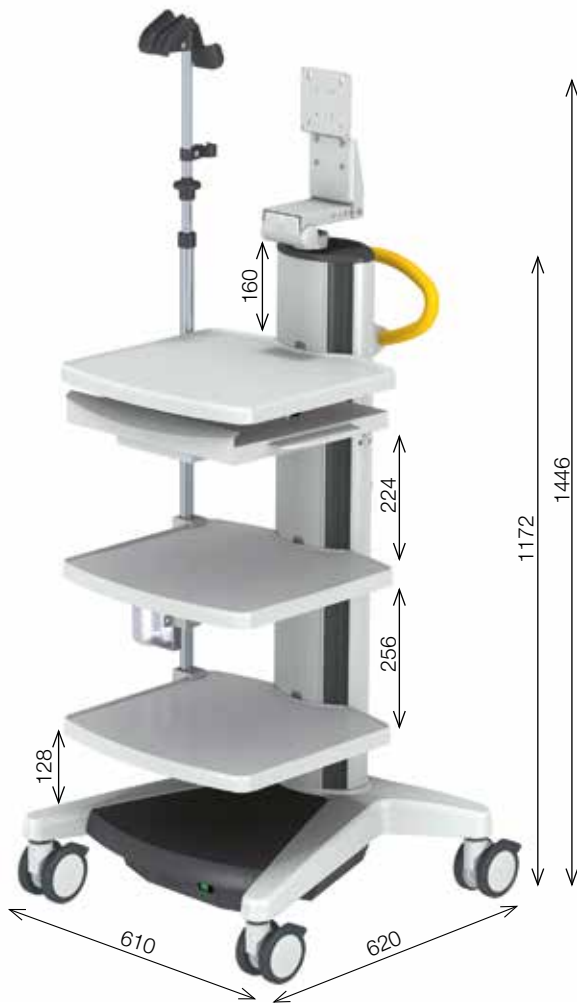

pro-cart

pro-cart video cart with isolating transformer

Item number: VT.4310.XXX¹⁾

Equipment cart, 30 U (Total height: 1172 mm), fitted with:

- 1 basic frame with 4 lockable twin castors Ø 100 mm
- 3 shelves
- 1 keyboard drawer with mousepad (left / right)
- 1 swivel and tilt monitor holder, adjustable, with VESA 75 / 100 adaptation up to 14 kg / 30.8 lbs
- 1 endoscope holder with clamp
- 1 drip glass
- 1 isolating transformer with 1200 VA and 6 equipotential bonding connectors (IEC320)
- 1 on / off switch on the isolating transformer
- 2 cable winders, rear
- 1 push handle, rear

Installation height: 30 U (960 mm)
Load capacity: 80 kg / 176 lbs
Finish: RAL 7035 light grey powder-coated
Decorative trims: push handle see ¹⁾
Scope of delivery: assembled

pro-cart PC-cart with isolating transformer

Item number: VT.4312.XXX¹⁾

Equipment cart, 30 U (Total height: 1172 mm), fitted with:

- 1 basic frame with 4 lockable twin castors Ø 100 mm
- 1 shelf with handle, front
- 1 keyboard drawer with mousepad (left / right)
- 1 block of drawers
- 1 twin monitor holder, universal, with VESA 75 / 100 adaptation up to 14 kg / 30.8 lbs
- 1 isolating transformer with 660 VA and 6 equipotential bonding connectors (IEC320)
- 1 on / off switch on the isolating transformer
- 2 cable winders, rear
- 1 push handle, rear

Installation height: 30 U (960 mm)
Load capacity: 80 kg / 176 lbs
Finish: RAL 7035 light grey powder-coated
Decorative trims: handle and push handle see ¹⁾
Scope of delivery: assembled

BASIC FRAME **pro-cart**

Basic frame **pro-cart**

As a result of its aluminium construction, the basic frame **pro-cart** provides a high load capacity with low weight. The shape of the base guarantees high torsional rigidity and stability as well as the space-saving integration of an isolating transformer. The large-volume support column enables secure storage of all electrical components. In addition, it provides an effective and orderly cable management without loss of major assembly stations. Four lockable twin castors ensure high comfort while in motion and secure operational fixture.

- Load capacity: 80 kg / 176 lbs
- Material: aluminium
- Finish: RAL 7035 light grey powder-coated
- Scope of delivery: 1 basic frame, assembled

pro-cart

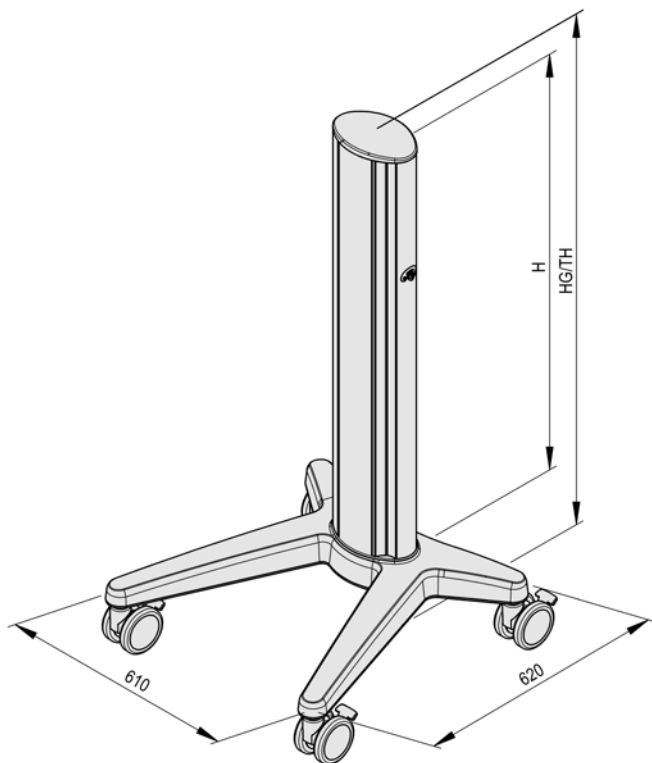

Installation height H	Total height TH	Castors Ø	Item number
21 U (672 mm)	884 mm	100 mm	PT.4000.991
30 U (960 mm)	1172 mm	100 mm	PT.4001.991
35 U (1120 mm)	1332 mm	100 mm	PT.4002.991
Counterweight set including basic trim			PT.2045.991

BASIC FRAME WITH MECHANICAL HEIGHT ADJUSTMENT FOR **pro-cart**

Basic frame with mechanical height adjustment **pro-cart**

By means of a height adjustment mechanism, your workplace can be operated either sitting or standing. The height adjustment is mounted at a height of 35 U at the front of the vertical extrusion of the basic frame **pro-cart**. When lifting loads, the mechanical height adjustment is helped by a gas spring. Components and accessories can be mounted at a height of 12 U in a grid of 32/64 mm on the height adjustment slide. The adjustment range is 300 mm and can be loaded with a weight of 3 to 10 kg / 6.6-22 lbs or from 10 up to 16 kg / 22 -35.2 lbs. Four lockable twin castors (Ø 100 mm) ensure high comfort while in motion and secure operational fixture.

- Total height:** 1332 mm when with castors Ø 100 mm
- Load capacity:** 80 kg / 176 lbs
- Material:** aluminium
- Finish:** RAL 7035 light grey powder-coated
- Scope of delivery:** 1 basic frame, assembled

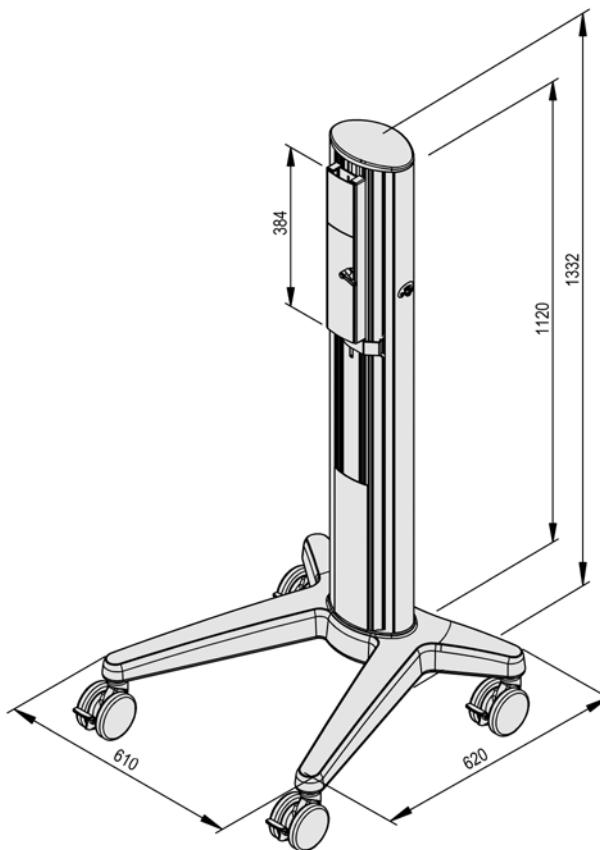

pro-cart

Designation	Load capacity of height adjustment	Item number
Basic frame with mechanical height adjustment	3-10 kg / 6.6-22 lbs	PT.4021.991
Basic frame with mechanical height adjustment	10-16 kg / 22-35.2 lbs	PT.4022.991

BASIC FRAME WITH ELECTRIC HEIGHT ADJUSTMENT **pro-cart**

Basic frame with electric height adjustment **pro-cart**

By means of a height adjustment mechanism, your workplace can be operated either sitting or standing. The height adjustment is mounted at the front of the vertical extrusion of the basic frame **pro-cart** at a height of 35 U. In the electric height adjustment, a linear drive helps raise and lower the load. This is operated via cable-connected remote control. Components and accessories can be mounted at a height of 12 U in a grid of 32/64 mm on the height adjustment slide. The adjustment range is 384 mm and can be loaded with a weight of up to 20 kg / 44 lbs. The linear actuator of the height adjustment can be operated at 110V or 230V. Four lockable twin castors (Ø 100 mm) ensure high comfort while in motion and secure operational fixture.

- Total height:** 1332 mm when with castors Ø 100 mm
- Load capacity:** 80kg / 176 lbs
- Material:** aluminium
- Finish:** RAL 7035 light grey powder-coated
- Scope of delivery:** 1 basic frame, 1 basic trim, assembled

pro-cart

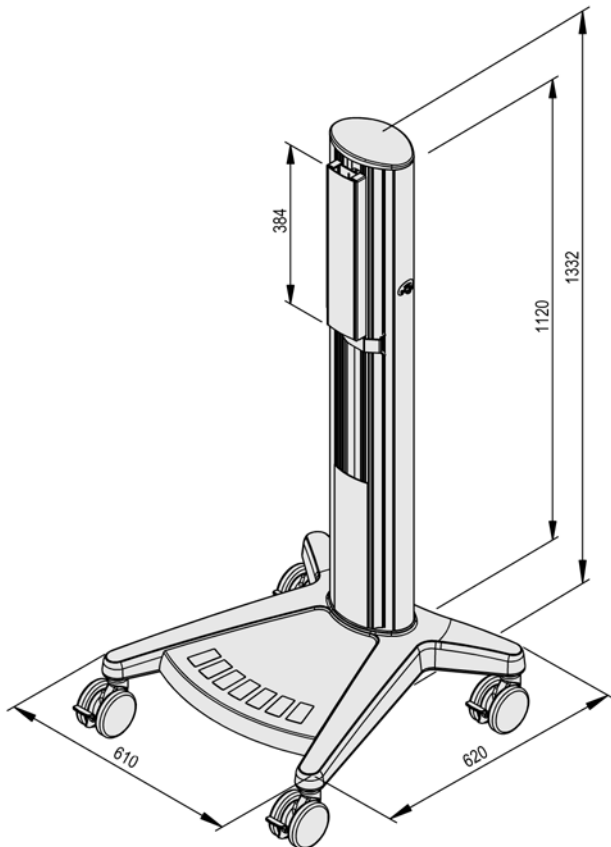

Designation	Load capacity of height adjustment	Input voltage	Item number
Basic frame with electric height adjustment	0-20 kg / 0-44 lbs	110 V and 50 / 60 Hz	PT.4023.991
Basic frame with electric height adjustment	0-20 kg / 0-44 lbs	230 V and 50 / 60 Hz	PT.4024.991

BASIC FRAME **pro-cart**

Castor conversion kit for basic frame **pro-cart**

For further requirements – as conversion kit instead of the specified standard design – the following castors are offered:

Scope of delivery: 1 castor conversion kit, 4 castors, each with wheel lock. Factory assembly only

Castor conversion kit	Instead of standard	Item number
Ø 100 mm, conductive	Ø 100 mm	ZV.9428.999
Ø 125 mm, conductive	Ø 100 mm	ZV.9923.999
Ø 125 mm, conductive	Ø 100 mm, conductive	ZV.9924.999
Wall protector		ZV.9964.999

Basic trim for **pro-cart**

The stylish basic trim provides a design element and is positioned between the front stabilisers. Moreover, it serves as a cover and mounting device for an isolating transformer.

Load capacity: 5 kg / 11 lbs distributed load
Material: plastic ABS
Finish: RAL 7043 traffic grey
Scope of delivery: 1 basic trim including mounting hardware



pro-cart

Designation	Item number
Basic trim for pro-cart	PT.2001.800

ISOLATING TRANSFORMER **pro-cart**

Isolating transformer for **pro-cart**

The isolating transformer is used to reduce the dangers for patients and professionals posed by leakage by providing insulation to the network. Single-fault protection and potential-free voltage supply is guaranteed by the use of the isolating transformer. This allows a constant power supply for electro-medical equipment and a safe patient environment. The isolation transformer is mounted between the two front stabilisers. The isolating transformer is optionally with insulation monitor available.

Power:	660 VA or 1200 VA
Input / Output voltage:	115 V / 115 V, 50 Hz / 60 Hz or 230 V / 230 V, 50 Hz / 60 Hz – switchable
Power input:	IEC 320 EURO input for use of country-specific power cables
Design:	toroidal transformer
Conditionally short circuit proof:	in conformity with IEC 742 and IEC 601-1
Inrush current limitation:	electronically regulated on nominal current
Safety class:	1
Insulation voltage:	PRI – earth: 1500 V, SEC – earth: 1500 V, PRI – SEC: 4000 V
Fuse protection:	primary 2-phase with micro fuse
Test:	CE labelling (for 660 VA, 1200 VA), NRTL-approval (for 1200 VA)
Protection class:	IP20
Material of enclosure:	steel
Finish:	RAL 7043 traffic grey powder-coated
Installation:	between two front stabilisers
Scope of delivery:	1 isolating transformer 660 VA or 1200 VA; basic trim; on / off switch; power cable earthed Schuko 5m; 6 equipotential bonding connectors (IEC320); plug removal barrier, pre-assembled. In case of integration of central on/off switch - factory assembly only

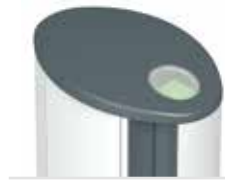

Isolating transformer for pro-cart	Power	Item number
Isolating transformer	660 VA	ZV.9356.999
Isolating transformer	1200 VA	ZV.9357.999

On / Off switch in the cover cap of support column	Item number
	PT.0290.999

Insulation monitor ELG (Earth Leakage Guard) for **pro-cart**

The isolation transformer for the **pro-cart** can be enhanced with the ELG insulation monitor, that is connected by simple plug and play technology and here a connector for the IEC power socket outlet is required. It gives out a visual and acoustic signal and the light-emitting diode and sound indicate that there is a critical fall in the isolation resistance of the whole system. This system does not replace the recommended regular tests and maintenance of those devices that are connected.

Supply voltage:	230 V / AC $\pm 15\%$
Operate value:	53 kOhm
Test resistance:	33 kOhm
AC internal resistance:	220 kOhm
DC internal resistance:	320 kOhm
Max. measuring voltage:	12 V
Max. measuring current:	< 0,5 mA
Max. external DC voltage:	250 V DC
Installation:	in the front T-slots of support column
Scope of delivery:	1 insulation monitor including cover strip and mounting hardware



Designation	Item number
Insulation monitor ELG for pro-cart	PT.2008.991

SOCKET STRIPS **pro-cart**

EURO socket strips with earthing contact for **pro-cart**

Ratings: 10 A / 250 VAC
Installation: in the support column
Scope of delivery: 1 EURO socket strip including mounting hardware



Designation	Connection cable	Standard	Item number
1 6-way, with external earthing contact	without	IEC 320	ZV.9433.999
2 6-way, with on/off switch in the support column, factory assembly only	without	IEC 320	ZV.9432.999
3 8-way, with external earthing contact	without	IEC 320	ZV.9375.999

The corresponding connection cable must be ordered separately and can be found in the Chapter Accessories.

Socket strip Schuko for **pro-cart**

Ratings: 16 A / 250 VAC
Installation: in the support column
Scope of delivery: 1 socket strip Schuko including mounting hardware



Designation	Connection cable	Standard	Item number
1 6-way, with external earthing contact	5 m	DIN VDE 0620-1	ZV.9435.999
2 6-way, with on/off switch in the support column, factory assembly only	without	DIN VDE 0620-1	ZV.9434.999

The corresponding connection cable must be ordered separately and can be found in the Chapter Accessories.

Socket strip French Standard for **pro-cart**

Ratings: 16 A / 250 VAC
Installation: in the support column
Scope of delivery: 1 socket strip French standard including mounting hardware



Designation	Connection cable	Standard	Item number
1 6-way, with external earthing contact	5 m	CEE7, UTE	ZV.9441.999
2 6-way, with on/off switch in the support column, factory assembly only	5 m	CEE7, UTE	ZV.9440.999

SHELVES pro-cart

Shelves for pro-cart

The shelves for the **pro-cart** are characterised by being spacious, with raised edges and rounded corners. The low installation height of 32 mm saves space and creates valuable space for other system components. Usable area of these shelves offers enough space for placing bigger devices. The shelves are available with various features such as handles or a mousepad. The integrated mousepad is extendable to the right and to the left. The handles are available in different colours.

- Installation height:** 1 U (32 mm)
- Dimensions:** 450 mm x 400 mm (W x D)
- Usable area:** 426 mm x 338 mm (W x D)
- Load capacity:** 20 kg / 44 lbs distributed load
- Material:** aluminium
- Finish:** RAL 7035 light grey powder-coated
- Decorative trims:** **handle** see ¹⁾
- Installation:** in the front T-slots of support column
- Scope of delivery:** 1 shelf including mounting hardware, pre-assembled



pro-cart

Designation	Item number
1 Shelf	PT.4100.991
2 Shelf with handle, front	PT.4101.XXX ¹⁾
3 Shelf with mousepad	PT.4102.991
4 Shelf with handle and mousepad	PT.4103.XXX ¹⁾

Universal shelf for pro-cart

The universal base can be ordered individually and adapted to the footprint of the device and is almost invisible.

- Installation height:** 2 U (64 mm)
- Dimensions:** 450 mm x 400 mm (W x D)
- Usable area:** 440 mm x 368 mm (W x D)
- Load capacity:** 10 kg / 22 lbs distributed load
- Material:** steel / aluminium
- Finish:** RAL 7035 light grey powder-coated
- Installation:** in the front T-slots of support column
- Scope of delivery:** 1 universal shelf including mounting hardware, pre-assembled



Designation	Item number
Universal shelf	PT.4111.991
Customised sizes are available on request	

DRAWERS pro-cart

Block of drawers for pro-cart

The **pro-cart** drawers are designed as a complete unit. They are characterised by providing a large storage space and a smooth removable inner body. The fully extendable technology maximises the storage space of the drawer and makes cleaning easier. The drawer block is fitted with a mechanical single locking lever that ensures that the drawer cannot open abruptly when approaching a threshold. Drawer blocks are available in different designs with handles or a mousepad. The integrated mousepad is extendable to the right and to the left.

Dimensions:	450 mm x 400 mm (W x D)
Usable area:	426 mm x 338 mm (W x D)
Interior area:	block of drawers: 340 mm x 240 mm x 80 mm (W x D x H) block of drawers high: 340 mm x 240 mm x 175 mm (W x D x H)
Load capacity:	shelf: 15 kg / 33 lbs distributed load, drawer: 3 kg /6.6 lbs distributed load
Material:	aluminium / plastic
Finish:	RAL 7035 light grey powder-coated
Decorative trims:	handles see ¹⁾
Installation:	in the front T-slots of support column
Scope of delivery:	1 block of drawers including mounting hardware, pre-assembled



pro-cart

Designation	Installation height	Item number
1 Block of drawers	4 U (128 mm)	PT.4104.XXX ¹⁾
2 Block of drawers with handle, front	4 U (128 mm)	PT.4105.XXX ¹⁾
3 Block of drawers with mousepad	4 U (128 mm)	PT.4106.XXX ¹⁾
4 Block of drawers with mousepad and handle, front	4 U (128 mm)	PT.4107.XXX ¹⁾
5 Block of drawers, 1 unit, high	7 U (224 mm)	PT.4113.XXX ¹⁾
6 Block of drawers, 1 unit, high with handle, front	7 U (224 mm)	PT.4114.XXX ¹⁾
7 Block of drawers, 2 units	7 U (224 mm)	PT.4130.XXX ¹⁾

KEYBOARD DRAWER / HANDLE **pro-cart**

Keyboard drawer with mousepad (left / right) for **pro-cart**

The keyboard drawer for the **pro-cart** can be extended by 260 mm and is mounted directly on the supporting column and usually placed under a storage shelf. When pulling out or pushing in the keyboard, the keyboard cable and the mouse are guided safely. The keyboard is prevented from slipping by two adjustable stops. The integrated mousepad can be pulled out both to the left and the right. The drawer is suitable for keyboards up to 200 mm in depth.

- Installation height:** 3 U (96 mm)
Load capacity: 3 kg / 6.6 lbs distributed load
Material: steel / aluminium
Finish: RAL 7035 light grey powder-coated
Installation: in the front T-slots of support column
Scope of delivery: 1 keyboard drawer including mounting hardware, pre-assembled

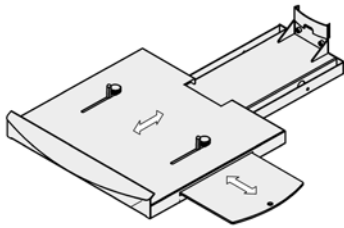

Designation

Item number

Keyboard drawer with mousepad (left / right)

PT.4108.991

Push handle for **pro-cart**

The pushing handle is mounted on the rear of the support column and creates a pushing position of 90 degrees offering plenty of legroom and a space-saving parking position at a 15 °-angle. The handle can also be mounted at a chosen height alongside the **pro-cart** support column.

- Material:** steel / aluminium / plastic
Finish: **mount:** plastic, RAL 7035 light grey; **push handle:** powder-coated
Decorative trims: **push handle** see ¹⁾
Installation: in the front T-slots of support column
Scope of delivery: 1 push handle including mounting hardware, factory assembly only



Designation

Item number

Push handle for **pro-cart**

PT.2000.XXX ¹⁾

MONITOR HOLDERS **pro-cart**

Monitor holder for **pro-cart**

Installation	On support column	At the front side of support column
VESA 75 / 100	 ± 20° tilt ± 170° swivel	 ± 20° tilt ± 20° swivel
	0-14 kg / 0-30.8 lbs PT.4143.991	0-14 kg / 0-30.8 lbs PT.4145.991
	14-18 kg / 30.8-39.6 lbs PT.4144.991	14-18 kg / 30.8-39.6 lbs PT.4146.991
VESA 75 / 100 universal	 ± 15° tilt ± 170° swivel	 ± 15° tilt ± 25° swivel
	0-14 kg / 0-30.8 lbs PT.4118.991	0-14 kg / 0-30.8 lbs PT.4138.991
VESA 75 / 100 adjustable	 ± 15° tilt ± 170° swivel	
	0-14 kg / 0-30.8 lbs PT.4119.991	
Universal adapter	Adapter plates for universal adapter on page 149  ± 15° tilt ± 170° swivel	
	0-14 kg / 0-30.8 lbs PT.4135.800	
Twin monitor holder, universal		 2 x ± 15° tilt ± 170° swivel
		0-14 kg / 0-30.8 lbs PT.4116.991
Twin monitor holder, adjustable		 2 x ± 15° tilt ± 170° swivel
		0-14 kg / 0-30.8 lbs PT.4117.991

pro-cart

Material: steel / aluminium
Finish: RAL 7035 light grey powder-coated, **universal adapter:** anodised
Scope of delivery: 1 monitor holder including mounting hardware